

PROFESSIONAL REFRIGERATORS



User's Manual

FR-110 / FR-110 G
FR-260 / FR-260 G
FRZ 300

Forced-ventilation, multifunctional **refrigerator** with microprocessor temperature controller.

Model	Description	Temperature range
FR-110	<i>Forced-ventilated solid door refrigerator 110 L (useful volume)</i>	+2 °C to + 8 °C
FR-110 G	<i>Refrigerator with glass door, forced ventilation 110 L (useful volume)</i>	+2 °C to + 8 °C
FR-260	<i>Forced-ventilated solid door refrigerator 260 L (useful volume)</i>	+2 °C to + 8 °C
FR-260 G	<i>Refrigerator with glass door, forced ventilation 260 L (useful volume)</i>	+2 °C to + 8 °C
FRZ-300 FR Units	<i>Combination freezer, forced-ventilation refrigerator unit 200 L (useful volume)</i>	+2 °C to + 8 °C

Builder:

Qingdao Carebios Biological Technology Co., Ltd.

No.433-5 Sancheng Road, Lancun Town,
Jimo District, Qingdao, Shandong., China

Drafting by the Agent:

Giorgio Bormac s.r.l.
Via della Meccanica, 25
41012 Carpi (MO)
V.A.T. 02309180368

Tel. +39 059 653274
Fax +39 059 653282
Email info@giorgiobormac.com

Summary

1. Safety information.....	5
• Definitions of Warning Words and Symbols	5
• Reporting deadlines:	5
• Warning symbols:.....	5
• Pictograms.....	5
• Danger Symbols.....	6
• Prohibition symbols.....	6
• Symbols of Obligation	6
2. General safety instructions	7
3. CE marking data	9
4. Package Contents	10
5. Transport.....	11
- Instructions for safe transport.....	11
• Transport of an already used refrigerator	11
6. Conservation	11
7. First installation	11
• Preliminary Operations	11
8. Instrument Parts.....	12
• Display and controls	13
• Display - Meaning of LEDs.....	13
• Display - Alarm Signalling	13
• Display - Other Signals.....	14

- **Commands**14
- **Switching on the instrument**15
- **Switching the interior light on and off**15
- **Display set point temperature**15
- **Change set point temperature**.....15
- **Change instrument sensitivity**15
- **Changing Instrument Units**15
- **Maximum and minimum temperature alarms**.....15
- **Maximum and minimum temperature display and storage function**16
- **Automatic and manual defrosting**16
- **Keypad lock**16
- **Set point probe calibration (offset)**16
- **Controller probe calibration (offset)**.....17
- **Door alarm**17
- **External contacts for remote alarms**.....17
- **Foot adjustment (for FR-110 and FR-11G)**.....17
- **Door inversion**17
- **Security lock**18
- **Installing and moving the shelf**.....18

11. Introduction of samples 19

- **Uploading Samples**19

12. Cleaning and Maintenance 20

- **Checking and cleaning the cooling unit compartment, heat sink and internal fan**20
- **Cleaning the outside of the instrument**20
- **Internal Instrument Cleaning**.....20

13. Warranty 21

14. Disposal of electronic equipment.....	21
15. Electrical diagram	22
16. Maintenance	22

1. Security Information

- **Definitions of warning words and symbols**

The safety information in this manual is very important in order to avoid personal injury, damage to the instrument, malfunction or incorrect results due to non-compliance. Please read this manual carefully in its entirety and make sure you familiarise yourself with the instrument before you start working with it. This manual must be kept near the instrument so that the operator can refer to it if necessary. Safety instructions are indicated by warning terms or symbols.

- **Reporting deadlines:**

CAUTION / WARNING / DANGER for a dangerous situation that could lead to serious injury reduced or medium, serious injury or death if not avoided.

NOTICE for important product information.

NOTES useful information.

- **Warning symbols:**

DANGER



This symbol indicates an **imminently hazardous** situation which, if not avoided, may result in death or serious (irreversible) injury.

WARNING



This symbol indicates a potentially dangerous situation which, if not avoided, may result in death or serious (irreversible) injury.

ATTENTION



This symbol indicates a potentially hazardous situation which, if not avoided, may result in minor or moderate (reversible) injury.

NOTICE



This symbol draws attention to possible damage to the instrument or instrumental parts.

NOTES











This symbol identifies useful product information.



- **Pictograms**

Within this manual there are different symbols identifying dangers, prohibitions and obligations as illustrated below.



- **Danger Symbols**

	Danger of electric shock
	Danger of explosion
	Fire hazard
	Danger of poisoning
	Danger of overheating surfaces
	Danger of damage to health caused by toxic substances
	Risk of injury from tipping objects
	Risk of injury from lifting heavy objects
	Danger of environmental damage
	Danger of corrosion

- **Prohibition symbols**







	Do not wet with water
---	-----------------------



- **Symbols of obligation**







	Disconnect the instrument from the power supply by pulling the plug
	Eye protection must be used

2. General safety instructions

If the refrigerator is not installed, commissioned, cleaned, adjusted or set up correctly, there is a risk of malfunctioning, which could lead to personal injury and material damage to the instrument and samples. Therefore, the refrigerator must only be installed, commissioned, cleaned, adjusted and set-up by qualified personnel.

 DANGER	
  	<p>Danger of electric shock and Danger of death</p> <ul style="list-style-type: none"> ⊘ Do not get the instrument wet during installation, commissioning or maintenance. ⊘ Do not connect the instrument to the power supply if the rear panel is dented or damaged. <p>➤ Before opening the rear panel, remove the plug from the power supply.</p> <p>➤ If the power cable or the rear panel of the instrument is damaged, stop using it immediately, unplug it from the power supply and contact your dealer for the necessary repairs.</p> <p>➤ All work on the electrical components of the instrument must only be carried out by qualified personnel.</p>
	<p>Danger of explosion</p> <p>➤ Only install the instrument where there is no risk of explosion.</p> <ul style="list-style-type: none"> ⊘ Do not keep air/solvent mixtures or explosive dusts nearby. ⊘ Never introduce materials into the instrument that are explosive or flammable at the selected operating temperature. ⊘ Never introduce materials containing flammable or explosive solvents into the instrument. ⊘ Never introduce materials into the instrument which by sublimation or pyrolysis result in the formation of flammable materials at the selected operating temperature.
 	<p>Danger of Poisoning and Danger of Death</p> <ul style="list-style-type: none"> ⊘ Never introduce materials into the instrument whose disintegration could result in the formation of poisonous gases at the selected operating temperatures.

 WARNING	
	<p>Fire hazard</p> <ul style="list-style-type: none"> ⊘ Do not place anything under the instrument (paper, plastic film, etc.). ➤ Always connect the instrument only to a fused power supply of at least 10A. Follow the recommendations of your local power supply company electrical. ⊘ Do not use naked flames near the instrument. ➤ The instrument contains a small amount of flammable hydrocarbons (R600a or R290).

 ATTENTION	
 	<p>Risk of injury and Danger of breakage</p> <ul style="list-style-type: none"> ➤ Always place the instrument only on surfaces that can support its weight.
	<p>Tipping hazard and Risk of injury</p> <ul style="list-style-type: none"> ⊘ Do not move the instrument when the front wheels are locked by the wheel block (in models with wheels). ➤ Check that there are no obstacles when handling the refrigerator.
  	<p>Risk of injury, Risk of slipping or tipping the instrument and Risk of damage to the instrument</p> <ul style="list-style-type: none"> ➤ The instrument must be handled by 2 persons. ➤ The instrument must only be transported in its original packaging. ➤ The instrument must be lifted using the original packaging from below with mechanical tools (e.g. forklift truck). ⊘ The instrument must not be lifted from its original packaging directly from below without mechanical tools (e.g. forklift truck). ⊘ The instrument must not be dragged by pulling the door.

3. CE marking data

Argolab instruments are manufactured in accordance with Directive 2006/42/EC and the relevant EU Directives applicable at the time of placing on the market (fac - simile below).

Qingdao Carebios Biological Technology Co.,Ltd.	DECLARATION OF CONFORMITY UE In accordance with Annex II A - Directive 2006/42/CE Annex IV - EMC Directive and Annex VI - Directive 2011/65/UE (RoHS)	
--	---	---

No. SHEM201201068901HSC

Manufacturer's Name : Qingdao Carebios Biological Technology Co.,Ltd.

Manufacturer's Address: No.433-5 Sancheng Road, Lancun Town, Jimo District, Qingdao, Shandong., China

Email: info@carebios.com

Authorised Representative : Giorgio Bormac S.r.l – Via della Meccanica, 25 41012 Carpi (MO)-ITAL

Object of Declaration: : Refrigerator

This declaration of conformity is issued under the sole responsibility of the manufacturer.

Product names:

Product description Refrigerator
 Model: KYC110G, KYC260G,
 Serial Number: KYCXXXXXXXXXX---KYCXXXXXXXXXX
 KYC0XXXXXXXXXX---KYC0XXXXXXXXXX

Product options: This declaration covers all options of the above products

- **The object of the declaration describe above complies with the essential requirements of the following applicable European Directives, and carries the CE marking accordingly:**

EMC directive: 2014/30/UE	<i>Directive 2014/30/EU of the European Parliament and of the Council of 26 February 2014 on the harmonization of the laws of the Member States relating to electromagnetic compatibility.</i>
RoHS Directive 2011/65/EU	<i>Directive 2011/65/EU of the European Parliament and of the Council of 8 June 2011 on the restriction of the use of certain hazardous substances in electrical and electronic equipment.</i>
LVD Directive: 2014/35/UE	<i>Directive 2014/35/EU of the European Parliament and of the Council of 26 February 2014 on the harmonization of the laws of the Member States relating to the making available on the market of electrical equipment designed for use within certain voltage limits Text with EEA relevance.</i>
Machinery Directive : 2006/42/EC	<i>DIRECTIVE 2006/42/EC OF THE EUROPEAN PARLIAMENT AND OF THE COUNCIL of 17 May 2006 on machinery, and amending Directive 95/16/EC (recast)</i>
Directive 2014/68 UE regarding PED	<i>Directive 2014/68/UE of European parliament and of council of 15 May 2014 concerning the harmonization of pressure equipment</i>

- **and conforms with the following standards:**

EN 61010-1:2010+A1:2019

EN 61326-1:2013

EN 61000-3-2:2014

EN 61000-3-3:2013

EN 60204:2018

EN ISO 12100:2010

NAME AND ADDRESS OF THE PERSON AUTHORISED TO COMPILE THE TECHNICAL FILE

Giorgio Bormac S.r.l. - Via della Meccanica, 25 41012 Carpi (MO) - ITALY

Signed for and on behalf of:

Place

QINGDAO

SIGNATURE _____

Facsimile of the CE marking plate:







4. Package Contents

The instrument will be delivered complete with the following parts:

1. Grids.
2. grid supports.
3. Power cable.
4. Instruction manual.
5. Locking keys

5. Transport

• Instructions for safe transport

 ATTENTION	
	Risk of injury, Risk of slipping or tipping the instrument and Risk of damage to the instrument
	<ul style="list-style-type: none">➤ The instrument must be handled by 2 persons.➤ The instrument must only be transported in its original packaging.➤ The instrument must always be lifted from below with mechanical tools (e.g. forklift truck) together with the supporting pallet.
	<ul style="list-style-type: none">⊘ The instrument must not be lifted directly from below with mechanical tools (e.g. forklift truck) without the supporting pallet.⊘ The instrument must not be moved by pulling the door.

• Transport of an already used refrigerator

- Switch off the Argolab instrument by operating the main switch.
- Remove the power plug from the socket.
- Remove the shelves.
- Clean the Argolab refrigerator and its shelves.
- Dry the inside of the Argolab instrument and the shelves.
- Wrap the shelves in bubble wrap.
- Pack the shelves in their original packaging and place them inside the Argolab instrument.
- Pack the entire Argolab instrument in its original packaging.
- ☒ Take care that the Argolab instrument does not get wet during transport.
- During transport, maintain the permitted ambient temperature (-10 °C to 60 °C).



6. Conservation

- Store the Argolab refrigerator only in closed, dry rooms.
- The permissible storage temperature is -10 °C to 60 °C, while the maximum permissible storage humidity is 85% RH in the absence of condensation.



7. First Installation

• Preliminary Operations

The instrument must be installed under the following conditions:

- Stable work surface with a horizontal, heat-resistant, dry and clean surface.
- Minimum spacing of at least 20 cm around the instrument.
- Ambient temperature between 5 °C and 35 °C and relative humidity not exceeding 85%.
- Avoid installing the instrument near heat sources (radiators, stoves, etc.).
- Install the refrigerator in a well-ventilated area, avoiding cramped rooms.
- Grounded power socket.
- Power supply 220/240 V - 50 Hz.
- If the instrument was transported in a horizontal position, wait 24 hours before switching on.

8. Instrument parts

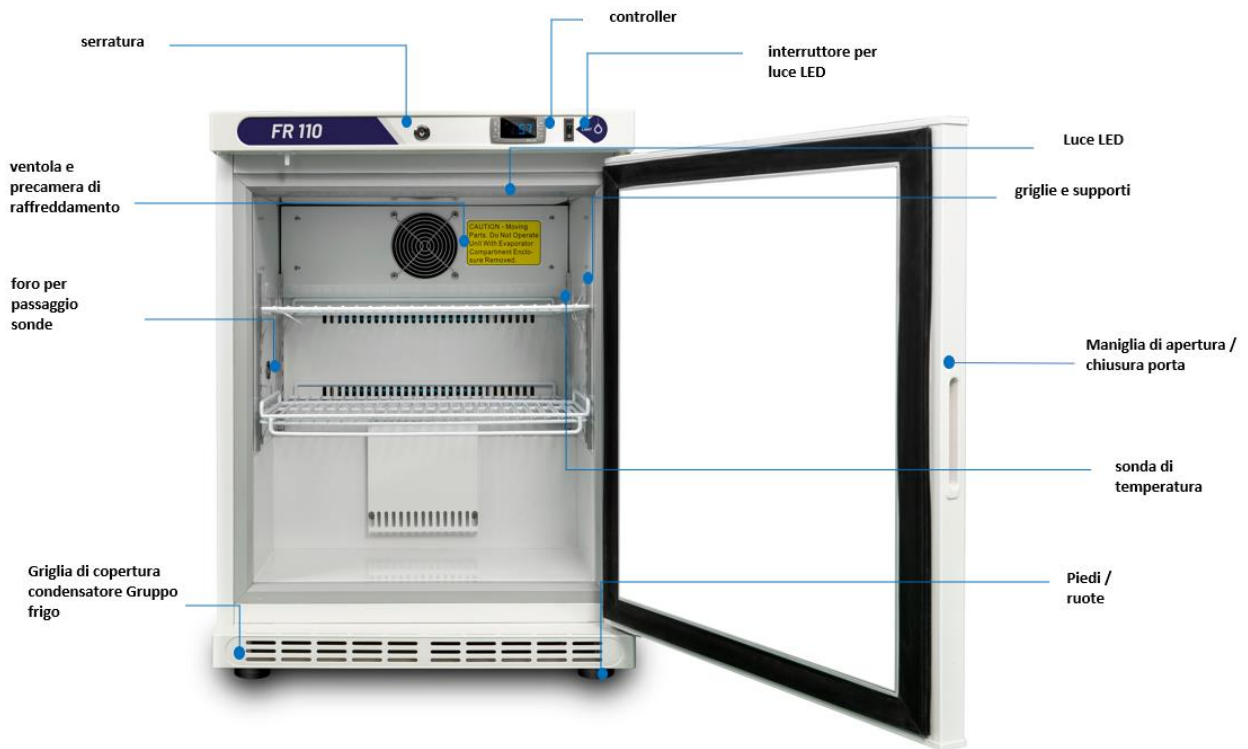

Figure 1 - front instrument

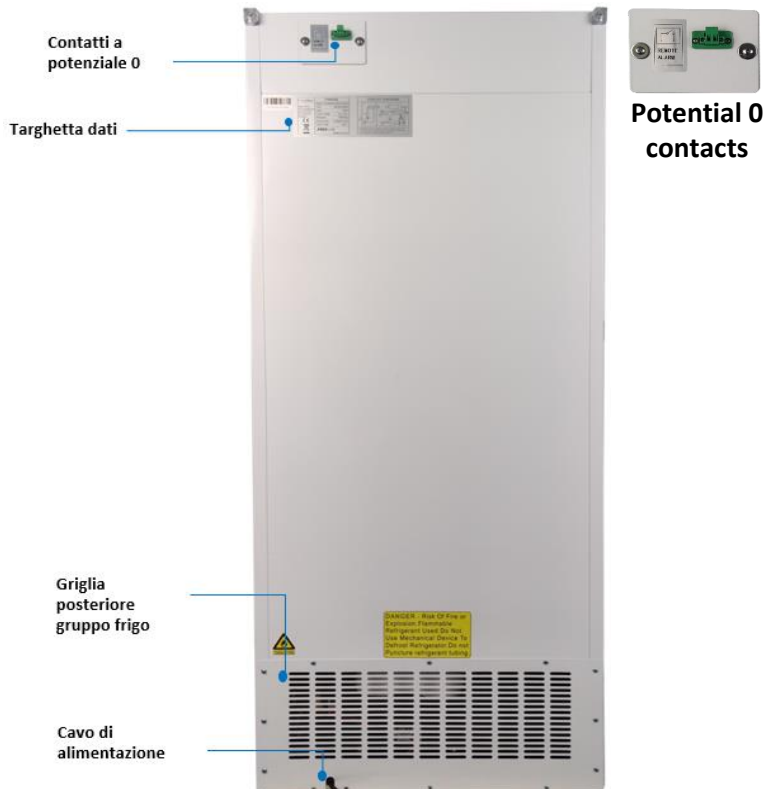

Figure 2 - rear instrument and potential-free contacts

- **Display and controls**



Figure 3 - Controller

- **Display - Meaning of LEDs**

LED IMAGE	MODE	SIGNIFICANCE
	Accessed	Active compressor
	Flashing light	Delay versus close start
	Accessed	Defrosting in progress
	Flashing light	Dripping in progress
	Accessed	A temperature alarm occurred
	Accessed	Units of Measurement
	Flashing light	Programming

- **Display - Alarm Signalling**

MESSAGE	CAUSE
"P1"	Faulty set point probe
"P4"	Controller probe faulty
"HA"	High temperature alarm
"LA"	Low temperature alarm
"EA"	External alarm
"dA"	Open door

NOTE: The temperature alarms and the external alarm automatically return as soon as the temperature returns to normal and a defrost cycle starts.





NOTE: The probe alarm goes off a few seconds after the probe fails; it automatically goes off again a few seconds after the probe resumes normal operation.



- **Display - Other signals**

MESSAGE	SIGNIFICANCE
Pon	Unlocking the keyboard
Pof	Locked keyboard

- **Commands**

COMMAND	DESCRIPTION
	(SBR) The defrost button allows you to manually start a defrost cycle.
SET	The SET button is used to set the working temperature (set point); in programming it selects a parameter or confirms a value.
	(DOWN) Allows you to see the data of a possible temperature alarm. In programming, it scrolls parameters and/or decreases their value Combined with the SET button, it allows you to enter programming Combined with the UP key, it allows the keyboard to be locked or unlocked
	(UP) Allows you to see the data of any temperature alarm In programming, it allows parameters to be scrolled through and/or values to be increased Combined with the SET button, it allows you to exit programming Combined with the DOWN key, it allows the keyboard to be locked or unlocked
	The ON/OFF button allows switching to standby mode (activation on demand).
	The ON/OFF light button allows the light inside the instrument chamber to be switched on and off. When the switch light is on, it indicates that the light inside the refrigerator is also on.

9. Technical Specifications

Fridge	FR-110	FR-110 G	FR-260	FR-260 G	FRZ 300 - Refrigerator Unit 200 L
Usable volume (litres)	110	110	260	260	200
Temperature range / resolution	2 ÷ + 8 / 0,1 °C	2 ÷ + 8 / 0,1 °C	2 ÷ + 8 / 0,1 °C	2 ÷ + 8 / 0,1 °C	2 ÷ + 8 / 0,1 °C
Defrosting works	Automatic and Manual	Automatic and Manual	Automatic and Manual	Automatic and Manual	Automatic and Manual
Temperature variation in space at 5°C *	1,3 °C	1,7 °C	1,9 °C	2,2 °C	1.0 °C (blind door) 1.2 °C (glass door)
Gradient at 5°C *	1,3 °C	1,7 °C	1,9 °C	2,6 °C	1.0 °C (blind door) 1.3 °C (glass door)
Recovery time at 5°C *	12 min	9 min	18 min	18 min	19 min
Controller / display	microprocessor/digital	microprocessor/digital	microprocessor/digital	microprocessor/digital	microprocessor/digital
Power supply	220 - 240 V	220 - 240 V	220 - 240 V	220 - 240 V	220 - 240 V
Inside dimensions (W x H x D)	500 x 570 x 420 mm	500 x 570 x 420 mm	500 x 1290 x 450 mm	500 x 1290 x 450 mm	510 x 730 x 490 mm
External dimensions (W x H x D)	600 x 805 x 560 mm	600 x 805 x 560 mm	600 x 1525 x 560 mm	600 x 1525 x 560 mm	600 x 1770 x 610 mm
Weight	50 Kg	50 Kg	75 Kg	75 Kg	75 kg
Number of shelves (standard / max.)	2 adjustable + 1 background / 3	2 adjustable + 1 background / 3	5 adjustable + 1 Background / 7	5 adjustable + 1 Background / 7	3 adjustable / 5
Minimum distance between shelves	13 mm	13 mm	13 mm	13 mm	13 mm
Maximum shelf load	15 Kg				
Door	Blind with lock	Lockable glass	Blind with lock	Lockable glass	Blind/glass with lock
Light	LED	LED	LED	LED	LED
Hole diameter for probe passage	10 mm	10 mm	10 mm	10 mm	10 mm
Power	120 W	120 W	160 W	160 W	340 W
Coolant	R 600a	R 600a	R 290	R 290	R 600a

* In accordance with EN 60068-3

* In accordance with DIN STANDARD 12880

10. Operation and features

- **Switching on the instrument**

Connect the power cable to a grounded power outlet, the instrument switches on.

NOTE: The  button does not switch off the instrument but activates the standby mode. Loads connected to the relays (e.g. remote alarm connections) continue to work.



- **Switching the interior light on and off**

To switch on the internal LED light, use the switch on the side of the controller.

The light switch has a small LED which, when on, indicates that the light inside the instrument is also on.

- **Display set point temperature**

Once the instrument is switched on, the display will show the temperature measured inside the instrument chamber in degrees Celsius and with sensitivity to a tenth of a degree.

The set point temperature can be displayed at any time by pressing the **SET** controller button.

- **Change set point temperature**

To change the set point press and hold the **SET** button on the controller for 2 sec., the display shows the set point and the LED with the °C symbol starts flashing; use the **UP** and **DOWN** buttons on the controller to change the set point as desired, wait 15 sec. or press the **SET** button on the controller to store the set point.

NOTE: In the hottest area of the inner chamber, the temperature may be higher than that indicated by the display.

- **Change the sensitivity of the instrument**

To change the sensitivity of the instrument: hold down the **SET** and **DOWN** buttons on the controller for 3 sec., the °C symbol on the display begins to flash; using the **UP** and **DOWN** buttons scroll through the parameters until parameter **rE.S** is displayed; press the **SET** button press and release the **SET** button on the controller and using the **UP** and **DOWN** buttons on the controller change the value from **dE** to **in**. To store the new value press the **SET** button on the controller or wait 15 sec.



- **Changing Instrument Units**

To change the unit of measurement from degrees Celsius to degrees Fahrenheit: press and hold down the **SET** and **DOWN** buttons on the controller for 3 sec., the °C symbol on the display starts flashing; use the **UP** and **DOWN** buttons to scroll through the parameters until parameter **CF** is displayed; press the **SET** button on the controller and use the **UP** and **DOWN** buttons on the controller to change the value from °C to °F. To store the new value press the **SET** button on the controller or wait 15 sec.

NOTE: 0°C = 32°F

NOTE: When using the instrument in °F, the instrument parameters will need to be adjusted, so please contact your instrument supplier.



- **Maximum and minimum temperature alarms**

Argolab refrigerators are equipped with modifiable maximum and minimum temperature alarms.

If the set maximum temperature (parameter **ALU**) is exceeded in the positive direction and the set minimum temperature (parameter **ALL**) is exceeded in the negative direction, the instrument will go into alarm by

signalling visual alarms ( + **HA** in the case of a high temperature alarm or **LA** in the case of a low temperature alarm), acoustic alarms and by closing the relay of the potential-free contacts located at the rear of the instrument.

To silence the audible alarm, press a button on the controller.

To change the maximum and/or minimum temperature alarm values press and hold down the **SET** and **DOWN** buttons on the controller for 3 sec., the °C symbol on the display will begin to flash; use the **UP** and **DOWN** buttons to scroll through the parameters until the **ALU** (high temperature alarm) and/or **ALL** (low temperature alarm) parameter is displayed, press and release the **SET** button on the controller and use the **UP** and **DOWN** buttons on the controller to change the desired value. To store the new value press the **SET** button on the controller or wait 15 sec. To exit the instrument parameter menu press the **SET** and **UP** buttons on the controller simultaneously or wait 15 sec. to return to the main display.

NOTE: Parameter values will be stored even in the absence of confirmation via the controller's **SET** button.



• Display and storage function for maximum and minimum temperatures

Argolab fridges store the maximum minimum temperatures reached.



To display the maximum temperature reached inside the instrument, press the **UP** button on the controller, the display shows item "Hi" followed by the maximum temperature reached by the instrument (including the temperature reached during defrosting). To display the minimum temperature reached inside the instrument, press the **DOWN** button on the controller, the display shows item "Lo" followed by the minimum temperature reached by the instrument. To delete the maximum and minimum temperatures memorised by the instrument, press and hold down the **SET** button for about 3 sec after displaying the maximum and minimum temperatures, the display shows word sSt, to confirm deletion of the values the word **sSt** starts flashing.



NOTE: The instrument only stores maximum and minimum temperatures when supplied with power.

• Automatic and manual defrosting

In addition to the automatic defrost function, each Argolab refrigerator has a manual defrost function with a dedicated button.

To start a defrost cycle, press and hold the  button on the controller for about 2 sec, the instrument starts the defrost cycle and the display shows the defrost symbol ().



• Keypad lock

To avoid incorrect instrument settings, the controller keyboard can be locked by holding down the **UP** and **DOWN** buttons for approx. 3 sec. The display shows 'POF' flashing. Once the controller has been locked, it will only allow the display to be shown; pressing one of the keys for about 3 sec. shows 'POF' on the display. To unlock the controller keyboard, press and hold the **UP** and **DOWN** buttons on the controller for approx. 3 sec.; the display shows "Pon".

• Set point probe calibration (offset)

To calibrate the instrument set point probe press and hold down the **SET** and **DOWN** buttons on the controller for approx. 3 sec., the display shows the °C symbol flashing; use the **UP** and **DOWN** buttons on the controller to scroll through the parameters until the **Ot** parameter is displayed. Press and release the **SET** button on the controller, the display shows the value of the original **Ot** parameter (Offset); set the desired value.

To calculate the temperature offset, follow the calculation below:

Sensed temperature - Set temperature on the fridge = temperature difference

Then algebraically add the obtained temperature difference to the original offset.

Ex:

Original offset= -2.2

Temperature measured= 5.5°C

Set temperature on the refrigerator = 5°C

Temperature difference = 5.5 - 5 = + 0.5°C

Corrected offset = +0.5 - 2.2 = - 1.7

NOTE: the instrument is equipped with a 10 mm diameter hole (with a silicone plug) dedicated to the passage of external probes.

• **Controller probe calibration (offset)**

To calibrate the temperature-sensing probe on the controller display, press and hold down the **SET** and **DOWN** buttons on the controller for approx. 3 sec., the display shows the °C symbol flashing; use the **UP** and **DOWN** buttons on the controller to scroll through the parameters until parameter **O4** is displayed.

Press and release the **SET** button on the controller, the display shows the value of the original parameter **O4** (Offset); set the desired value.

To calculate the temperature offset, follow the calculation below:

Sensed temperature - Set temperature on the fridge = temperature difference

Then algebraically add the temperature difference obtained to the original offset.

Ex:

Original offset= 0.2

Temperature measured= 4.8°C

Display temperature = 5°C

Temperature difference = 4.8 - 5 = -0.2°C

Corrected offset = -0.2 - 0.2 = 0

NOTE: the instrument is equipped with a 10 mm diameter hole (with a silicone plug) dedicated to the passage of external probes.

• **Door alarm**

To prevent damage to stored products, Argolab refrigerators are equipped with a switch installed on the instrument door. If the door is open for longer than 5 min, the instrument emits an acoustic and visual alarm ('**da**') and closes the relay of the potential-free contacts on the rear side of the instrument. It is possible to change the delay set in the instrument (5 minutes): hold down the **SET** and **DOWN** buttons on the controller for approx. 3 sec., the display shows the °C symbol flashing; using the **UP** and **DOWN** buttons on the controller scroll through the parameters until the **did** parameter is displayed. Change this parameter by indicating the number of minutes after which you want the instrument to go into alarm.



• **External contacts for remote alarms**

On the rear side of the instrument (Figure 2), there are potential-free contacts for external alarms (normally open). When the instrument goes into alarm, it will close the external remote alarm contacts. An alarm signalling system can be connected to the potential-free contacts.

• **Foot adjustment (for FR-110 and FR-11G)**

The FR-110 and FR-110 G models are equipped with height-adjustable feet.

It is useful to adjust the feet in case of unevenness of the floor; misalignment of the instrument could lead to possible deformation of the door by altering its closure. correctly.

• **Door reversal**

All Argolab refrigerator models are equipped with reversible doors.

Procedure for door reversal:

1. Remove, by unscrewing the screws using a Phillips screwdriver, the condenser cover grille (Figure 1)
2. Unscrew, using a Phillips screwdriver, the bottom hinge canton of the door
3. Pull the door out from below
4. Remove and reverse, using a Phillips screwdriver, the upper pin and lower cantilever hinge of the dismantled door
5. Slide the door onto the refrigerator from below, with the components reversed, securing the new top pin in the housing
6. Insert the lower door hinge into the bottom bracket of the refrigerator
7. Turn the door 90° and screw in the support screw, the spring will tension.

- **Security lock**

Every Argolab refrigerator is equipped with a safety lock above the door.

BLOCKING OF THE DEVICE:

1. Slipping the key into the lock
2. Turn the key 90° anti-clockwise in the direction.



- **Installing and moving the shelf**

Each Argolab refrigerator is equipped with shelves, No. 4 blocks for each shelf and No. 4 side supports on which to fix the blocks. To move the shelves:

1. Removing the shelf
2. lift the blocks inserted in the holes of the side supports, the block will slide about 10 mm into the hole of the side support
3. rotate the lower pin of the blocks by approximately 45°.
4. remove the blocks by pulling out the upper pins.

Repeat the above steps backwards to secure the blocks on the side supports.

11. Introduction of samples

 DANGER	
	<p>Danger of explosion and Danger of death</p> <ul style="list-style-type: none"> ⊗ Never introduce materials into the instrument that are explosive or flammable at the selected operating temperature. ⊗ Never introduce materials containing flammable or explosive solvents into the instrument. ⊗ Never introduce materials into the instrument which by sublimation or pyrolysis result in the formation of flammable materials at the selected operating temperature.
	<p>Danger of Poisoning and Danger of Death</p> <ul style="list-style-type: none"> ⊗ Never introduce materials into the instrument whose combustion could result in the formation of poisonous gases. ⊗ Never introduce materials into the instrument that can react with moisture and form explosive gases.

• Uploading Samples

In order to achieve optimal air circulation inside the Argolab refrigerator chamber, it is recommended to leave gaps between the samples (see Figure 4). For proper convection of the samples, it is recommended not to place them in direct contact with the walls of the instrument chamber.

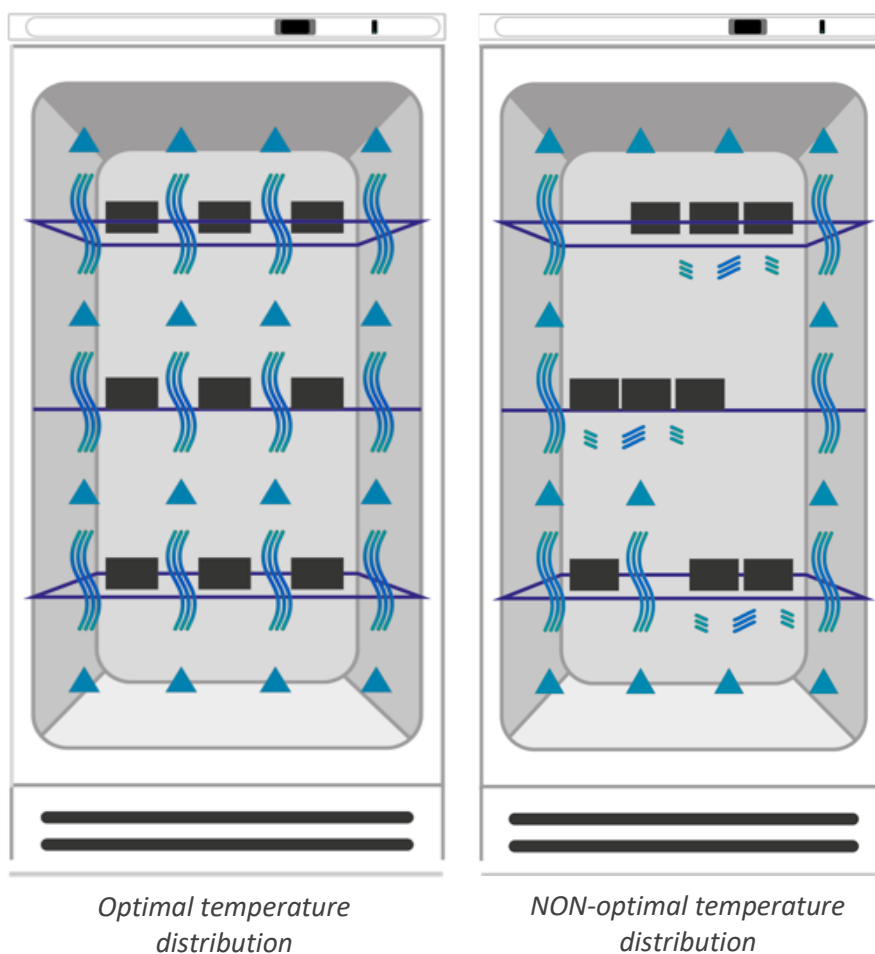

Figure 4 - positioning of samples

12. Cleaning and Maintenance

Proper maintenance and cleaning of the instrument ensures its good condition.

- **Checking and cleaning the cooling unit compartment, heatsink and the internal fan**

It is recommended that the refrigerating unit, heat sink and internal fan be cleaned once a year. To check the refrigeration unit compartment and its components it is necessary to interrupt the operating cycle, switch off the instrument by disconnecting the power cable from the electrical socket. Then wait until the refrigerator parts reach room temperature (at least 30 minutes) before proceeding with the inspection. Remove the bottom grill panel at the front of the instrument (Figure 1) by unscrewing the fixing screws and access the compartment. Check that the compartment of the refrigeration unit and the various components are clean, in particular check that the heat sink surface is well cleaned and has no bent metal fins. If cleaning is necessary, take particular care not to bend these fins. It is recommended to use a normal vacuum cleaner, but be careful to keep the suction nozzle at a distance. For the other parts, use a soft cloth and a non-aggressive and/or corrosive detergent, not in pure form but always diluted with water. Replace the front grille panel (Figure 1) in its place and tighten the fixing screws.



IMPORTANT: If the instrument is to be sent for service, it should be properly cleaned and possibly decontaminated from pathogens. It is also recommended to return the instrument in its original packaging to the repair service. In the absence of the original packaging, please make sure that it is properly packed for transport. Any damage caused by incorrect shipment will not be covered by warranty.

- **Cleaning the outside of the instrument**





It is not necessary to interrupt the operating cycle to clean the external surfaces of the instrument.





Be equally careful not to inadvertently disconnect or damage the power cable.

It is recommended to clean the external surfaces with a normal all-purpose cleaner sprayed on a soft, dampened cloth, so that it is not concentrated. Before proceeding with cleaning or any decontamination, the user must ensure that the method adopted does not damage the instrument.

- **Internal instrument cleaning**

To completely clean the instrument and its shelves, it is necessary to interrupt the operating cycle and switch off the instrument using the switch on the display. Before cleaning, open the instrument and wait until the internal chamber reaches room temperature. The internal chamber of the instrument is made of coated steel, so it can be cleaned with any detergent as long as it is not aggressive and/or corrosive. It is recommended to clean the internal surfaces with a normal all-purpose cleaner sprayed on a soft dampened cloth, so that it is not concentrated. Before proceeding with any cleaning or decontamination, the user must ensure that the method adopted does not damage the instrument.

 DANGER	
  	<p>Danger of electric shock and Danger of death</p> <ul style="list-style-type: none"> Ø DO NOT spray water or detergents on external surfaces. Ø Turn off the main switch and disconnect the mains plug before cleaning. <p>➤ Dry the device completely before switching it on again.</p>

 ATTENTION	
	<p>Danger of corrosion - Damage to equipment</p> <ul style="list-style-type: none"> Ø DO NOT use cleaning agents containing halogen acids. Ø DO NOT use detergent on other surfaces (e.g. on the galvanised parts of the hinges or on the rear wall of the outer structure).
  	<p>Eye contact - Eye damage caused by chemical burns</p> <ul style="list-style-type: none"> Ø DO NOT discharge into the sewage system. <p>➤ Wear protective goggles.</p>

13. Warranty

Under normal conditions of use, this instrument is guaranteed for a period of 36 months from the date of purchase.

The guarantee is only valid if the purchased product remains original. It does not apply to any product or parts thereof that have been damaged due to incorrect installation, improper connections, misuse, accident, lack of maintenance and abnormal conditions of use. We accept no liability for damage caused by use not in accordance with instructions, lack of maintenance and any unauthorised modifications.

14. Disposal of electronic equipment

This equipment is subject to regulations for electronic devices.

Dispose of in accordance with existing local regulations.



15. Electrical diagram

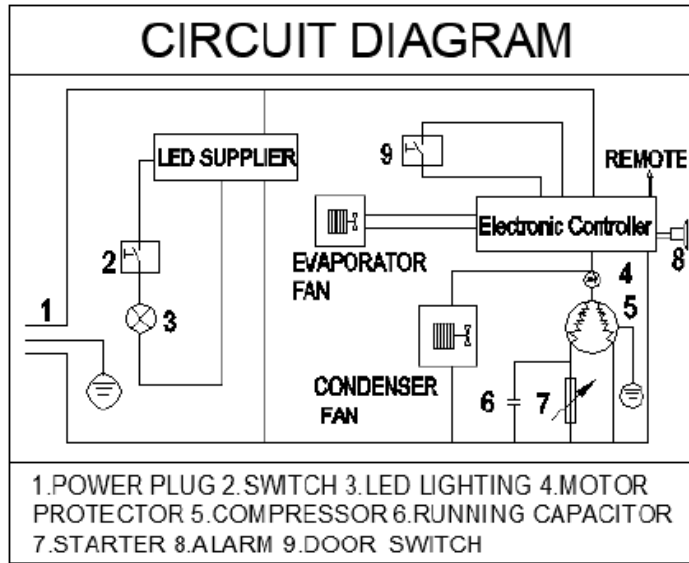

16. Maintenance

Should the product develop faults, please observe the table below before contacting technical support.

Fault	Possible causes	Solution
The refrigerator does not work	Not properly connected	Check the correct power supply of the device
	The power cable is damaged	Contact technical support or specialist technician
	Power supply	Check the power supply
	Damaged internal electrical cables	Contact technical support or specialist technician
The refrigerator turns on but the temperature is too high or too low	Refrigeration unit condenser clogged or dirty	Clean condenser
	Door not closed properly	Check that the door is properly closed and that its seal is not damaged
	The device was installed in the vicinity of heat sources and in cold air	Move the device to a more suitable environment
	Ambient temperature too high	Increase ventilation within the room or place the device in an air-conditioned environment
	Internal fan blocked	Remove obstacles obstructing the device fan
	Too many products inside the instrument	Reduce the amount of product inside the device
	Incorrect internal parameters	Contact technical support
Internal LED light does not light up	Damaged internal electrical cables	Contact technical support or specialist technician
The device is noisy	The device touches nearby objects	Check the device installation and change it if necessary
	The device is not properly stable	Check installation and change if necessary